



CAR

CA103



PRODUCT INFORMATION



Product Line	●	Themed
User Ages	●	3-12
User Capacity	●	28
Fall Height	●	150cm
Dimension	●	485cm x 760cm
Safety Area	●	83m ²
Safety Dimension	●	785cm x 1060cm
Maximum Height	●	400cm
Weight	●	779kg
Safety Certificate	●	EN 1176-3

PRODUCT DESCRIPTION

The Car series, in which the coolest car designs and details are used, includes climbing and sliding functions. The user can take his place in the game, either as a fast driver or as a cop chasing him. The product develops basic motor skills and enables the user to socialize.

ACTIVITIES



Sliding



Climbing



Running



Sitting



Socializing



Crawling





CAR CA103



PRODUCT SPECIFICATION



Number of
Users
•
28



Number of
Roofs
•
1



Number of
Slides
•
4



Number of
Entrances
•
3

COLOR PALETTE



MATERIAL SPECIFICATION

- Main construction is made of steel pipes, diameter 114mm and thickness 2.5mm.
- Platforms are made of steel sheet which has 2mm thickness and covered with PVC plastisol.
- Roof, slide and panels are made of medium-density polyethylene material with the rotation technique.
- Stair treads are made of sheet coated by plastisol rubber. Stair railings are made of medium-density polyethylene with the rotation technique.
- Pipe and profile openings are covered with plastic injection caps.
- The metal surfaces of the product have been cleaned by sandblasting, washing, rinsing, and drying and it has been painted with electrostatic powder coating.
- Screws are covered with plastic caps.
- Product doesn't have sharp edges and surfaces.
- Product has been produced in accordance with EN1176 standards.
- Please contact to Polfisan for updated information about product.

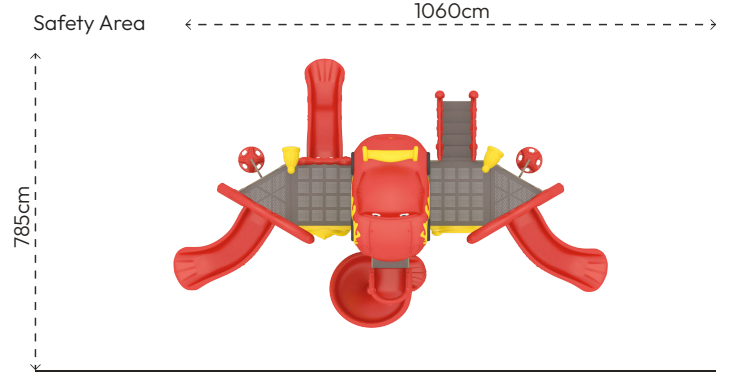

Top View



Side View



Front View

