



DINO PARK

HD152



PRODUCT INFORMATION



Product Line	●	Digital
User Ages	●	3-12
User Capacity	●	45
Fall Height	●	210cm
Dimension	●	942cm x 1173cm
Safety Area	●	211m ²
Safety Dimension	●	1342cm x 1573cm
Maximum Height	●	750cm
Weight	●	kg
Safety Certificate	●	EN 1176-3

PRODUCT DESCRIPTION

The Dino Park series is adorned with images that will take little users to the era when dinosaurs ruled the earth, featuring a colossal ancient world filled with dinosaurs we've always known but never seen.

With Dino Park bringing the past to the present, the goal is to welcome the little explorers to a world full of new discoveries and excitement.

ACTIVITIES



Sliding



Climbing



Running



Sitting



Role Play



Thinking



Hand Skill



Socializing





DINO PARK

HD152



PRODUCT SPECIFICATION



Number of Users
•
45



Number of Roofs
•
1



Number of Slides
•
4



Number of Entrances
•
4

COLOR PALETTE



MATERIAL SPECIFICATION

- Main construction is made of steel pipes, diameter 89mm and thickness 3mm.
- Platforms are made of 18mm plywood.
- Roof, railings and panels are made of HPL (High Pressure Laminate) and UV-protected Polycarbonate panels, which are resistant to all weather conditions.
- It is produced using digital printing with high-quality UV curing inks that are resistant to all weather conditions.
- Slide surface is high-strength HDPE material with 15mm thickness. Slide walls are made of HPL.
- Tube slide is made of medium-density polyethylene material in a tunnel shape and transparent polycarbonate.
- Rope is made of polypropylene braided steel rope, diameter 16mm with 6 steel rope helices.
- Pipe and profile openings are covered with plastic injection caps.
- The metal surfaces of the product have been cleaned by sandblasting, washing, rinsing, and drying; zinc primer has been applied to increase corrosion resistance, and it has been painted with electrostatic powder coating.
- Screws are covered with plastic caps.
- Product doesn't have sharp edges and surfaces.
- Product has been produced in accordance with EN1176 standards.
- Please contact to Polfisan for updated information about product.

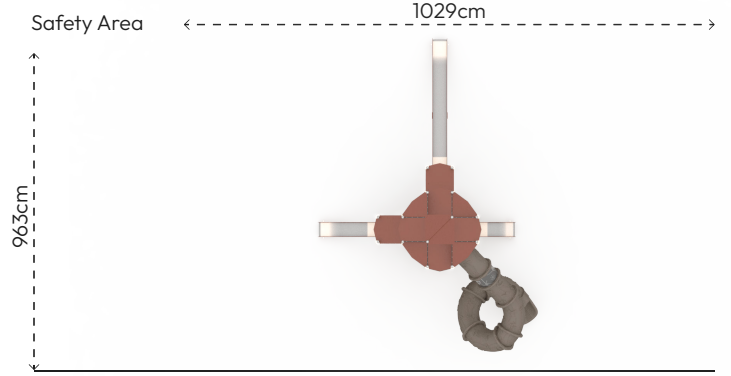

Top View



Side View

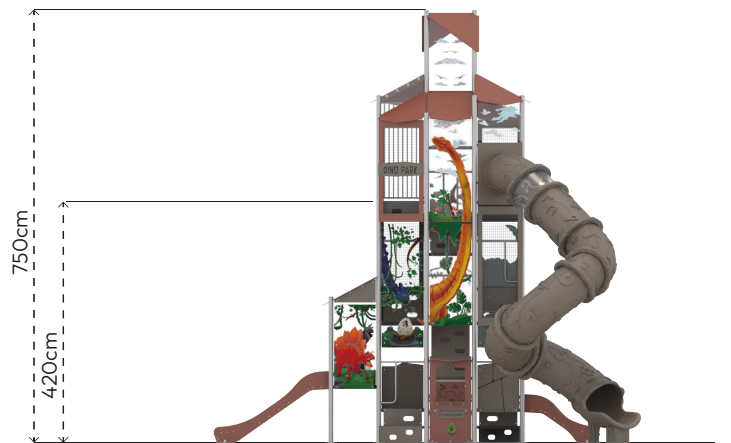

Front View

