



NATURE FREESTANDING

KZ603-T-SWINGO



PRODUCT INFORMATION



Product Line	● Nature
User Ages	● 7-12
User Capacity	● 2
Fall Height	● 120cm
Dimension	● 175cm x 420cm
Safety Area	● 51m ²
Safety Dimension	● 825cm x 620cm
Maximum Height	● 280cm
Weight	● 362kg
Safety Certificate	● EN 1176-1

PRODUCT DESCRIPTION

Tower pipes, which are the product's main components, swing products made of wood composite material, and a large body that can rotate 360 degrees and oscillate in all directions are designed for a wide range of users. The tower pipes, which are the product's main component, are made of wood composite material.

ACTIVITIES



Balance



Swing



Spinning



Sitting



Team Play



Socializing

Address: Yukarı Eğercili Mahallesi, Atatürk Bulvarı, No:122 Çarşamba/SAMSUN Post Code: 55500

Tel: +90 362 266 66 96 polfisan@polfisan.com.tr www.polfisan.com.tr



Made in Türkiye



NATURE FREESTANDING

KZ603-T-SWINGO



PRODUCT SPECIFICATION



Number of Users
•
2



Number of Roofs
•
0



Number of Slides
•
0



Number of Entrances
•
0

COLOR PALETTE



MATERIAL SPECIFICATION

- Main construction is made of steel pipes, diameter 89,9mm and thickness 2,5mm.
- The product uprights are wood-like composite material with a diameter of 114 mm and a thickness of 12 mm, which covers a steel pipe with a diameter of 89,9 mm, manufactured by extrusion method.
- Pipe and profile openings are covered with plastic injection caps.
- Polyamide connectors are used for assembly at the contact points of the pipes.
- Plastic seat is made of medium-density polyethylene material.
- The metal surfaces of the product have been cleaned by sandblasting, washing, rinsing, and drying and it has been painted with electrostatic powder coating.
- Screws are covered with plastic caps.
- Product doesn't have sharp edges and surfaces.
- Product has been produced in accordance with EN1176 standards.
- Please contact to Polfisan for updated information about product.

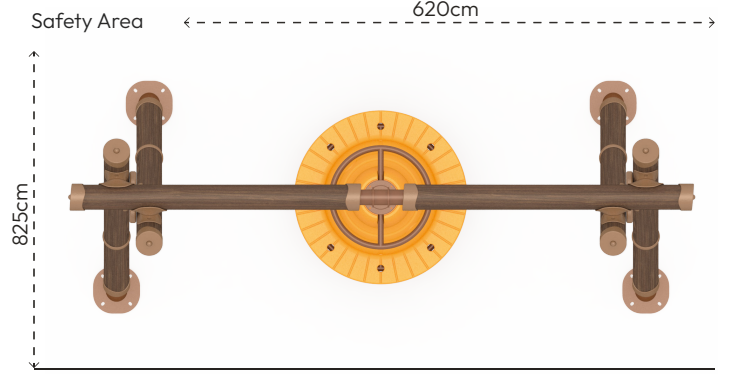

Top View



Side View



Front View

